

Complex Kerr Geometry, Twistors and the Dirac Electron

A Burinskii

Gravity Research Group NSI Russian Academy of Sciences. B. Tulskaia 52,
Moscow 115191, Russia

E-mail: bur@ibrae.ac.ru

Abstract. The Kerr-Newman spinning particle displays some remarkable relations to the Dirac electron and has a reach spinor structure which is based on a twistorial description of the Kerr congruence determined by the Kerr theorem. We consider the relation between this spinor-twistorial structure and spinors of the Dirac equation, and show that the Dirac equation may naturally be incorporated into Kerr-Schild formalism as a master equation controlling the twistorial structure of Kerr geometry. As a result, the Dirac electron acquires an extended space-time structure having clear coordinate description with natural incorporation of a gravitational field. The relation between the Dirac wave function and Kerr geometry is realized via a chain of links: *Dirac wave function* \Rightarrow *Complex Kerr-Newman Source* \Rightarrow *Kerr Theorem* \Rightarrow *Real Kerr geometry*. As a result, the wave function acquires the role of an “order parameter” which controls spin, dynamics, and twistorial polarization of Kerr-Newman space-time.

PACS numbers: 11.27.+d, 03.65.-w, 04.40.-b

1. Introduction

The fact that Kerr-Newman solution has gyromagnetic ratio $g = 2$ as that of the Dirac electron [1] created the treatment of this solution as a classical model of an extended electron in general relativity [1, 2, 3, 4, 5, 6, 7, 8, 9, 10, 11, 12, 13, 14]. If this coincidence is not occasional, one has to answer a fundamental question: what is the relation of the Dirac equation to the structure of the Kerr-Newman solution? Contrary to the Dirac electron, the Kerr-Newman spinning particle has clear space-time structure which is concordant with gravitational field.

One can argue that the gravitational field of an electron is negligibly weak and can be ignored. However, one cannot ignore the extremely large spin/mass ratio (about 10^{44} in the units $\hbar = c = G = 1$,) which shows that the correct estimations of the gravitational effects have to be based on the Kerr-Newman solution. Results of corresponding analysis are rather unexpected [15, 16] and differ drastically from the estimations performed on the base of spherically symmetric solutions. Although the local averaged gravity is very weak, the extremely high spin leads to the very strong polarization of space-time and to the corresponding very strong deformation of electromagnetic (em-) field which has to be aligned with the Kerr congruence. Since the em-field of electron cannot be considered as small, the resulting influence turns out to be very essential. In particular, the em-field turns out to be singular at the Kerr

singular ring which has the Compton size. Moreover, the Kerr-Newman space-time with parameters of an electron is topologically not equivalent to the flat Minkowski space-time, acquiring two folds with a branch line along the Kerr ring. It shows that the Kerr geometry gives some new background for the treatment of this problem. In fact, the Kerr solution gives us some complementary coordinate information which has a natural relation to gravity and displays independently the special role of the Compton region.

The aim of this paper is to set an exact correspondence between the operators of polarization and momentum of an electron in the Dirac theory and similar relations for the momentum and spin of the Kerr spinning particle:

$$\textit{Dirac equation} \Rightarrow \textit{wave function} \Rightarrow \textit{Kerr Geometry}. \quad (1)$$

As a result, we obtain a model, in which electron has the extended space-time structure of Kerr-Newman geometry and *the Dirac equation is considered as a master equation controlling dynamics and polarization of this structure.*‡

Our treatment is based on the initiated by Newman [17] complex representation of the Kerr geometry, in which a ‘point-like’ source of the Kerr-Newman solution is placed in a complex region and propagates along a complex world-line $X^\mu(\tau)$ in a complexified Minkowski space-time CM^4 .

It was shown [18, 19] that a natural and rigorous treatment of this construction may only be achieved in the Kerr-Schild formalism [3] which is based on the metric decomposition $g_{\mu\nu} = \eta_{\mu\nu} - 2Hk_\mu k_\nu$ containing auxiliary Minkowski space-time M^4 with metric $\eta_{\mu\nu}$. This auxiliary M^4 is complexified to CM^4 and can be used as a natural space-time for the complex Kerr source as well as for the Kerr null vector field $k^\mu(x)$, ($x = x^\mu \in M^4$), forming the Kerr congruence via Kerr theorem [18, 19, 20, 21].

The Kerr theorem determines the Kerr congruence in M^4 from a holomorphic generating function $F(Z)$ in terms of projective twistor coordinates Z^α . The relation of the Kerr geometry to twistors is not seen in Boyer-Lindquist coordinates, but it turns out to be profound in the Kerr-Schild formalism. Although the terms ‘twistor’ and ‘Kerr theorem’ were absent in the seminal paper [3], they were practically used there for derivation of the Kerr-Schild class of solutions via the chain of relations

$$F(Z) \Rightarrow Y(x) \Rightarrow k^\mu \Rightarrow g_{\mu\nu}, \quad (2)$$

where the twistor coordinates

$$Z^\alpha = (Y, \quad \zeta - Yv, \quad u + Y\bar{\zeta}) \quad (3)$$

are defined via the null Cartesian coordinates

$$2^{\frac{1}{2}}\zeta = x + iy, \quad 2^{\frac{1}{2}}\bar{\zeta} = x - iy, \quad 2^{\frac{1}{2}}u = z - t, \quad 2^{\frac{1}{2}}v = z + t. \quad (4)$$

The variable Y plays a special role, being the projective spinor coordinate $Y = \phi^2/\phi^1$ and, simultaneously, the projective angular coordinate

$$Y = e^{i\phi} \tan \frac{\theta}{2}. \quad (5)$$

Therefore, the output of the Kerr theorem, function $Y(x)$, determines the field of null directions $k^\mu(x^\mu)$ in M^4 . This field forms a vortex of twisting null congruence, each geodesic line of which represents the twistor $Z^\alpha = \textit{const}$.

‡ In fact we arrive at some stochastic version of one-particle quantum theory with hidden structure, similar to theories with hidden parameters.

To match the Dirac solutions with the Kerr congruence we select two special twistor lines going via the center of the solution, $(t, x, y, z) = (0, 0, 0, 0)$, and corresponding to $Y = 0$ and $Y = \infty$. For the Kerr solution in a standard position, these lines form two semi-infinite axial beams directed along the positive ($\theta = 0$) and negative ($\theta = \pi$) z -axis. They are determined by two two-component spinors which we set corresponding to the four-component Dirac spinor of the wave function of the Dirac equation in a Weyl basis. In this case the spin-polarization and momentum of the Dirac electron matches with the spin and momentum of the Kerr spinning particle [13, 22]

Such a relation is simple for the standard orientation of the Kerr-Newman solution and the standard treatment of the Dirac equation for a free electron. However, in the more general cases (a moving electron, or electron in an external electromagnetic field) the null vectors formed by the Dirac bispinor components turn out to be independent, and the corresponding selected null beams take independent orientation. It leads to the deformation of the Kerr twistorial structure which is determined by some generating function of the Kerr theorem. Thus, to set the correspondence (1) in a general case, one has to use the Kerr theorem involving the complex-world-line (CWL) representation of Kerr geometry. The corresponding chain of relations takes the form

$$\text{Dirac equation} \Rightarrow \text{wave function} \Rightarrow \text{CWL} \Rightarrow F_q \Rightarrow Y(x) \Rightarrow \text{Kerr Geometry}$$

which is valid for a weak and slowly varying electromagnetic field, which is the case compatible with the validity of one-particle Dirac theory. The relation between CWL and parameters q of the Kerr generating functions F_q was investigated in [19, 23], and in this paper we consider the missing link $\text{Dirac equation} \Rightarrow \text{wave function} \Rightarrow \text{CWL}$ which allows one to consider Dirac equation as a *master equation*, controlling the polarization and dynamics of the Kerr geometry corresponding to the wave function of the considered electron.

One more aspect of our treatment concerns the wave properties of electron. It was obtained long ago that stationary Kerr-Newman solution may only be considered as a first approximation, and some extra electromagnetic and spinor wave excitations on the Kerr background are necessary to generate the wave properties of the Dirac electron. Because of that, from the beginning this model was considered as a model of ‘microgeon with spin’ [4], in which the Kerr-Newman solution represents only solution for some averaged fields on the Kerr background. It was observed [22, 10] that the treatment of the electromagnetic or spinor wave excitations on the Kerr background leads to the inevitable appearance of extra axial singular lines resembling the singular strings of the Dirac monopole. Moreover, the wave excitations of the Kerr circular singularity induce de Broglie periodicity on the axial singular lines [13, 22]. It stimulated investigation of the wave analogs of the Kerr-Newman solutions, which is related with generalization of the known Kerr-Schild class of solutions by treatment of some extra function γ which was set to zero in the general Kerr-Schild formalism. This is a very hard unsolved problem, and in this paper we concentrate attention on special exact singular solutions ‘chirons’ which acquire a wave generalization, being asymptotically exact for the weak and slowly varying electromagnetic excitations [24].

We keep mainly the Kerr-Schild notations [3] for Kerr geometry and spinor notations of the book [25]. The following two sections represent a brief description of the structure of Kerr solution following the papers [11, 13, 19].

2. Real structure of the Kerr geometry

The angular momentum of an electron $J = \hbar/2$ is extremely high with respect to the mass, and the black hole *horizons disappear*, opening the naked Kerr singular ring. This ring is a branch line of the space which acquires two-fold topology. It was suggested [4] that the Kerr singular ring represents a string which may have some excitations generating the spin and mass of the extended particle-like object – ‘microgeon’.

The skeleton of the Kerr geometry is formed by *the Kerr principal null congruence* which represents a twisted family of the lightlike rays – twistors. The null vector field $k^\mu(x)$, which is tangent to these rays, determines the Kerr-Schild form of metric

$$g^{\mu\nu} = \eta^{\mu\nu} + 2Hk^\mu k^\nu, \quad (6)$$

where $\eta^{\mu\nu}$ is the auxiliary Minkowski metric with coordinates $x^\mu = (t, x, y, z)$. The vector potential of the Kerr-Newman solution is aligned with this congruence

$$A_\mu = er(r^2 + a^2 \cos^2 \theta)^{-1} k_{\mu,}, \quad (7)$$

and the Kerr singular ring represents its caustic.

The Kerr theorem [20, 21, 18, 19, 26] claims that *any holomorphic surface in the projective twistor space CP^3 with coordinates*

$$Z^\alpha = (Y, \lambda^1, \lambda^2), \quad \lambda^1 = \zeta - Yv, \quad \lambda^2 = u + Y\bar{\zeta} \quad (8)$$

determines the geodesic and shear-free null congruence in M^4 . Such congruences lead to solutions of the Einstein-Maxwell field equations with metric (6) and an em-field in the form (7). The congruence of the Kerr solution is built of the straight null generators, twistors, which are (twisting) null geodesic lines (possible trajectories of photons). Therefore, for any holomorphic function $F(Z^\alpha)$, solution $Y(x^\mu)$ of the

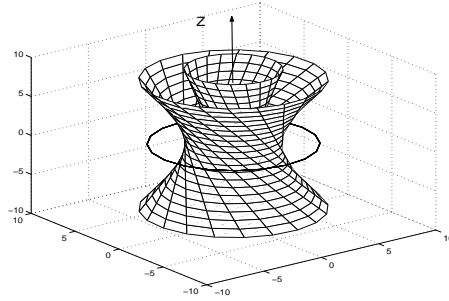

Figure 1. The Kerr singular ring and congruence.

equation $F(Y, \lambda_1, \lambda_2) = 0$ determines congruence of null lines in M^4 by the form

$$e^3 = du + \bar{Y}d\zeta + Yd\bar{\zeta} - Y\bar{Y}dv, \quad (9)$$

and the null vector field tangent to congruence is $k_\mu dx^\mu = P^{-1}e^3$. § Function Y is related to projective spinor, $Y = \phi_2/\phi_1$, and null vector field k^μ may be represented in spinor form $k_\mu = \bar{\phi}_{\dot{\alpha}} \bar{\sigma}_{\mu}^{\dot{\alpha}\alpha} \phi_\alpha$.

§ Here k^μ and Y are functions of $x^\mu = (t, x, y, z) \in M^4$, and $P = P(Y, \bar{Y})$ is a normalizing factor related with the boost of Kerr source.

3. Complex representation of the Kerr geometry

The complex source of Kerr geometry is obtained as a result of complex shift of the ‘point-like’ source of the Schwarzschild solution in the Kerr-Schild form. There are also the Coulomb and Newton analogs of the Kerr solution.

Applying the complex shift $(x, y, z) \rightarrow (x, y, z + ia)$ to the singular source $(x_0, y_0, z_0) = (0, 0, 0)$ of the Coulomb solution q/r , Appel in 1887(!) obtained the solution $\phi(x, y, z) = \Re q/\tilde{r}$, where $\tilde{r} = \sqrt{x^2 + y^2 + (z - ia)^2}$ turns out to be complex. On the real slice (x, y, z) , this solution acquires a singular ring corresponding to $\tilde{r} = 0$. It has radius a and lies in the plane $z = 0$. The solution is conveniently described in the oblate spheroidal coordinate system r, θ , where

$$\tilde{r} = r + ia \cos \theta. \quad (10)$$

One can see that the space is twofold having the ring-like singularity at $r = \cos \theta = 0$ as the branch line. Therefore, for the each real point $(t, x, y, z) \in \mathbf{M}^4$ we have two points, one of them is lying on the positive sheet, corresponding to $r > 0$, and another one lies on the negative sheet, where $r < 0$.

It was obtained that Appel potential corresponds exactly to electromagnetic field of the Kerr-Newman solution written in the Kerr-Schild form, [4]. The vector of complex shift $\vec{a} = (a_x, a_y, a_z)$ corresponds to the angular momentum of the Kerr solution.

Newman and Lind [17] suggested a description of the Kerr-Newman geometry in the form of a retarded-time construction, where it is generated by a complex point-like source, propagating along a *complex world line* $X^\mu(\tau)$ in a complexified Minkowski space-time \mathbf{CM}^4 . The rigorous substantiation of this representation is possible only in the Kerr-Schild approach [3] based on the Kerr theorem and the Kerr-Schild form of metric (6) which are related to the auxiliary \mathbf{CM}^4 [19, 18, 23].

In the rest frame of the Kerr particle, one can form two null 4-vectors $k_L = (1, 0, 0, 1)$ and $k_R = (1, 0, 0, -1)$, and represent the 3-vector of complex shift $i\vec{a} = i\Im m X^\mu$ as the difference $i\vec{a} = \frac{ia}{2}\{k_L - k_R\}$. The straight complex world line corresponding to a free particle may be decomposed to the form

$$X^\mu(\tau) = X^\mu(0) + \tau u^\mu + \frac{ia}{2}\{k_L - k_R\}, \quad (11)$$

where the time-like 4-vector of velocity $u^\mu = (1, 0, 0, 0)$ can also be represented via vectors k_L and k_R ,

$$u^\mu = \partial_t \Re e X^\mu(\tau) = \frac{1}{2}\{k_L + k_R\}. \quad (12)$$

One can form two complex world lines related to the complex Kerr source,

$$X_+^\mu(t + ia) = \Re e X^\mu(\tau) + iak_L^\mu, \quad X_-^\mu(t - ia) = \Re e X^\mu(\tau) - iak_R^\mu, \quad (13)$$

which allows us to match the Kerr geometry to the solutions of the Dirac equation.

3.1. Complex Kerr string

The complex world line $X^\mu(\tau)$ is parametrized by the complex time parameter $\tau = t + i\sigma$ and represents a world sheet. Therefore, $X^\mu(t, \sigma)$ is a very specific string extended along the imaginary time parameter σ . The Kerr-Newman null congruence and corresponding gravitational and electromagnetic fields are obtained from this

string-like source by a retarded-time construction which is based on the complex null cones, emanated from the worldsheet of this complex string [9, 13]. In particular, the real twistors of the Kerr congruence represent a real slice of the null generators of these null cones [9, 19]. The complex retarded time equation $t - \tau = \tilde{r}$ takes the form

$$\tau = t - r + ia \cos \theta. \quad (14)$$

The real sections of the complex cones correspond to the real coordinates t, r, θ . It yields the relation

$$\sigma = a \cos \theta \quad (15)$$

between the points of worldsheet and angular directions of twistor lines. Since $|\cos \theta| \leq 1$, we conclude that the string is open and has the end points, corresponding to $\cos \theta = \pm 1$ and to two complex world lines $X_+^\mu = X^\mu(t + ia)$ and $X_-^\mu = X^\mu(t - ia)$. By analogue with the real strings, where the end points are attached to quarks, one can add the Chan-Paton factors to the end points X_\pm^μ of the complex Kerr string and identify them as quarks [11, 13].

The complex cones positioned at these end points have the *real slice in the form of two real twistors* corresponding with the above discussed null directions k_L^μ and k_R^μ which determine momentum and spin-polarization of the Kerr solution. These twistors have the limiting values of angular direction $\cos \theta = \pm 1$, and form two half-strings of opposite chirality aligned with the axis of symmetry z.

3.2. Chirons and excitations of the Kerr singular ring

The twistor coordinate Y is also the projective angular coordinate

$$Y = e^{i\phi} \tan \frac{\theta}{2} \quad (16)$$

covering the celestial sphere $Y \in CP^1 = S^2$. Electromagnetic field of the exact

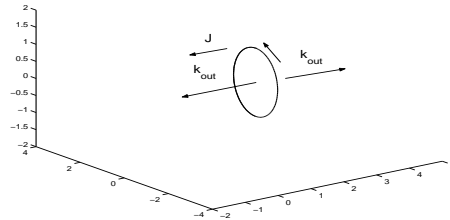

Figure 2. The Kerr singular ring and two special twistors.

stationary Kerr-Schild solutions, [3], is determined by vector potential which may be represented in the form

$$A^\mu = \Re \mathcal{A}(Y)(r + ia \cos \theta)^{-1} k^\mu, \quad (17)$$

where $\mathcal{A}(Y)$ is an arbitrary analytical function of Y . In general, $\mathcal{A}(Y)$ may contain the poles in different angular directions Y of the celestial sphere S^2 , which causes the appearance of semi-infinite singular rays – axial strings [22]. The elementary solutions are $\mathcal{A}(Y) = eY^{-n}$. The simplest case $\psi = e = \text{const.}$ gives the Kerr-Newman solution.

The case $n = 1$ leads to a singular line along the positive semi-axis z . Due to the factor $e^{i\phi}$ in Y , the em-field has winding number $n=1$ around this axial singularity. Since there is also pole at singular ring, $\sim (r + ia \cos \theta)^{-1}$, the em-field has a winding of phase along the Kerr ring. The solution with $n = -1$ has opposite chirality and singular line along the negative semi-axis z . The elementary exact solutions ('chirons') have also the wave generalizations $\mathcal{A} = eY^{-n}e^{i\omega\tau}$ acquiring the extra dependence from the complex retarded time τ , [22]. The wave chirons are asymptotically exact in the low-frequency limit [24] and describe the waves propagating along the Kerr singular ring, as it was assumed in the old 'microgeon' model [4]. Such waves may also be considered as em-excitations of the Kerr closed string [11]. The two axial half-strings are not independent: the boundary conditions of the complex Kerr string demands its orientifolding by identification of the initiate worldsheet and the worldsheet with reverse parametrization [9, 13]. Orientifolding is accompanied by the reverse of space and antipodal map $\bar{Y} \rightarrow -1/Y$, which displays antipodal relation between the singular half-strings and also between the corresponding chirons. Notice that by a lorentz boost the axial half-strings acquire modulation by de Broglie periodicity [22, 13].

4. Dirac equation in the Weyl basis

In the Weyl basis the Dirac spinor has the form $\Psi = \begin{pmatrix} \phi_\alpha \\ \chi^{\dot{\alpha}} \end{pmatrix}$, and the Dirac equation splits into

$$\sigma_{\alpha\dot{\alpha}}^\mu (i\partial_\mu + eA_\mu)\chi^{\dot{\alpha}} = m\phi_\alpha, \quad \bar{\sigma}^{\mu\dot{\alpha}\alpha} (i\partial_\mu + eA_\mu)\phi_\alpha = m\chi^{\dot{\alpha}}. \quad (18)$$

The conjugate spinor has the form

$$\bar{\Psi} = (\chi^+, \phi^+) = (\bar{\chi}^\alpha, \bar{\phi}_{\dot{\alpha}}). \quad (19)$$

The Dirac current

$$J_\mu = e(\bar{\Psi}\gamma_\mu\Psi) = e(\bar{\chi}\sigma_\mu\chi + \bar{\phi}\bar{\sigma}_\mu\phi), \quad (20)$$

can be represented as a sum of two lightlike components of opposite chirality

$$J_L^\mu = e\bar{\chi}\sigma^\mu\chi, \quad J_R^\mu = e\bar{\phi}\bar{\sigma}^\mu\phi. \quad (21)$$

The corresponding null vectors

$$k_L^\mu = \bar{\chi}\sigma^\mu\chi, \quad k_R^\mu = \bar{\phi}\bar{\sigma}^\mu\phi, \quad (22)$$

determine the considered above directions of the lightlike half-strings. The momentum of the Dirac electron is $p^\mu = \frac{m}{2}(k_L^\mu + k_R^\mu)$, and the vector of polarization of an electron [27, 25] in the state with a definite projection of spin on the axis of polarization is $n^\mu = \frac{1}{2}(k_L^\mu - k_R^\mu)$. In particular, in the rest frame and the axial z -symmetry, we have $k_L = (1, \vec{k}_L) = (1, 0, 0, 1)$ and $k_R = (1, \vec{k}_R) = (1, 0, 0, -1)$, which gives $p^\mu = m(1, 0, 0, 0)$, and $n^\mu = (0, 0, 0, 1)$, which corresponds to the so-called transverse polarization of electron [27], $\vec{n}\vec{p} = 0$.

By the Lorentz boost \vec{v} , the spinors χ and ϕ transform independently [28]

$$\chi' = \exp(-\sigma_v \frac{w}{2})\chi, \quad \phi' = \exp(-\sigma_v \frac{w}{2})\phi, \quad (23)$$

where $\sigma_v = (\vec{\sigma} \cdot \vec{v})/|v|$ and $\tanh w = v/c$. The Dirac spinors form a natural null tetrad. The null vectors $k_L^\mu = \bar{\chi}\sigma^\mu\chi$ and $k_R^\mu = \bar{\phi}\bar{\sigma}^\mu\phi$, may be completed to the null tetrad by two null vectors $m^\mu = \phi\sigma^\mu\chi$, and $\bar{m}^\mu = (\phi\sigma^\mu\chi)^+$ which are controlled by the phase of wave function. Therefore, the de Broglie wave sets a synchronization of the null tetrad in the surrounding space-time, playing the role of an 'order parameter'.

5. Dirac equation as a master equation controlling twistorial polarization

Obtaining the relation between the Dirac wave function and Complex World Line (CWL), we have to set other missing links in our long chain of the relations discussed in the introduction. First, let us recall the relation $F \Rightarrow \text{Kerr Geometry}$. The used in [3] generating function $F(Y, \lambda^1, \lambda^2)$ leading to the Kerr-Newman solution had the form

$$F \equiv a_0 + a_1 Y + a_2 Y^2 + (qY + c)\lambda^1 - (pY + \bar{q})\lambda^2, \quad (24)$$

where a_0, a_1, a_2 are complex constants which determine spin orientation, the coefficients c, p, q, \bar{q} , determine the Killing vector (or the boost) of the solution and the related function

$$P = -pY\bar{Y} - \bar{q}\bar{Y} - qY - c. \quad (25)$$

Since $\lambda^1 = \zeta - Yv$, $\lambda^2 = u + Y\bar{\zeta}$, function F is quadratic in Y and has the general form $F = AY^2 + BY + C$, which allows to find two roots of the equation $F(Y) = 0$,

$$Y^\pm = (-B + \Delta^\pm)/2A, \quad \Delta^\pm = \pm(B^2 - 4AC)^{1/2}, \quad (26)$$

and represent function $F(Y)$ in the form

$$F = A(Y - Y^+)(Y - Y^-). \quad (27)$$

Following [3, 19] we can determine

$$PZ^{-1} = -\partial F/\partial Y = 2AY + B, \quad (28)$$

which turns out to be a complex radial distance $\tilde{r} = r + ia \cos \theta$,

$$\tilde{r}^\pm = -PZ^{-1} = 2AY^\pm + B = \Delta^\pm. \quad (29)$$

The two solutions for Y and \tilde{r} reflect the known twofoldedness of the real Kerr geometry and correspond to two different sheets of the real Kerr space-time with different congruences.

In the case of arbitrary position, spin orientation and boost, the generating function F is controlled by the set of parameters $q = (a_0, a_1, a_2, c, q, \bar{q}, p)$ and may be represented as $F_q = A_q Y^2 + B_q Y + C_q$. The relation of the coefficients A, B, C with parameters of CWL (11) was given in [19, 23]:

$$\begin{aligned} A &= (\bar{\zeta} - \bar{\zeta}_0)\dot{v}_0 - (v - v_0)\dot{\zeta}_0; \\ B &= (u - u_0)\dot{v}_0 + (\zeta - \zeta_0)\dot{\zeta}_0 - (\bar{\zeta} - \bar{\zeta}_0)\dot{\zeta}_0 - (v - v_0)\dot{u}_0; \\ C &= (\zeta - \zeta_0)\dot{u}_0 - (u - u_0)\dot{\zeta}_0, \end{aligned} \quad (30)$$

where the parameters of CWL are expressed in the null coordinates (4), in accordance with the correspondence

$$(u_0, v_0, \zeta_0, \bar{\zeta}_0) \leftrightarrow X^\mu(0) + \frac{ia}{2}\{k_L - k_R\}, \quad (\dot{u}_0, \dot{v}_0, \dot{\zeta}_0, \dot{\bar{\zeta}}_0) \leftrightarrow \dot{X}^\mu(\tau) = \frac{1}{2}\{k_L + k_R\}.$$

It restores the full chain of relations between the values of the Dirac wave function and polarization of the Kerr geometry.

The obtained relationship $\text{Dirac theory} \Rightarrow \text{Kerr geometry}$ may be interpreted in the frame of some version of one-particle quantum theory. For example, the plane

Dirac wave does not give information on the position of electron, but gives exact information on its momentum and spin-polarization. The center of corresponding Kerr-Newman geometry may be localized at any point of space-time, but the considered model gives a definite orientation of spin and corresponding deformation of the Kerr congruence caused by momentum (Lorentz boost). If the wave function is formed by a wave packet and localized in some restricted region which is much greater than the Compton length, we have a value of the normalized Dirac bispinor $\Psi = \begin{pmatrix} \phi_\alpha(x) \\ \chi^{\dot{\alpha}}(x) \end{pmatrix}$, at the point $x \in M^4$ and corresponding density of probability $w(x) = \bar{\chi}(x)\chi(x) + \bar{\phi}(x)\phi(x)$ for position of the Kerr geometry, and the obtained relationships say that with the density $w(x)$ electron is positioned at this point and has at this point a definite polarization of the Kerr-Newman geometry which is determined by values $\chi(x)$ and $\phi(x)$. Therefore, we arrive at some stochastic version of quantum theory containing hidden parameters, more precisely – a hidden space-time structure.

The relationship *Dirac theory* \Rightarrow *Kerr geometry* is one-sided, since it regards the *Dirac equation as a master equation* and does not give anything new for the Dirac theory itself besides of its interpretation. At the same time it gives some new useful relations to Kerr-Newman solution, allowing us to determine its behavior in a weak and slowly varying external electromagnetic field via the solutions of Dirac equation.

On the other hand, the considered twistorial structure of electron is based on the local field theory and allows one to conjecture that there is indeed a relation of this model to multi-particle quantum field theory which gives a more detailed description of electron. The author expects that at least some of the mysteries and problems of the modern QED may be understood and cured in this way. In particular, the em-field of the Kerr-Schild solutions $F_{\mu\nu}$ is to be aligned with the Kerr congruence, obeying the constraint $F_{\mu\nu}k^\mu = 0$. The twistorial structure of the Kerr-Schild solutions determines polarization of the em field, providing a caustic on the Kerr singular ring. Consequently, elementary electromagnetic excitation aligned with the Kerr background shall lead to the appearance of waves propagating along the Kerr ring and, simultaneously, to the appearance of the induced singular axial pp-waves [22]. All that has to be also valid for the vacuum fluctuations [24], and the field of virtual photons is to be concentrated near the Kerr singular ring, forming excitation of this ring which may be considered as a closed string. || Therefore, the model of electron based on the fields aligned with the Kerr twistorial structure supports the conjecture that the string-like source of the Dirac-Kerr electron, having the Compton size, should be *experimentally observable*.

It seems that there is a more simple way to apply Kerr geometry, considering the Dirac equation on the Kerr background [14]. However, in spite of the separability of Dirac equation on the Kerr background, the corresponding exact wave solutions are unknown for the case of nonzero mass term. There are also some theoretical arguments showing that the exact massive solutions on the Kerr background, aligned with the Kerr congruence, don't exist at all, because of the twosheetedness of the Kerr space-time.

It should also be noted, that all the wave em-solutions aligned with the Kerr background demonstrate the appearance of singular beams. Such singular beams also appear inescapably in the spinor wave solutions [10, 14], which disables the necessary

|| It was shown that the fields around the Kerr string are similar to the fields around a heterotic string obtained by Sen as a solution to low-energy string theory [29, 11]. However, it has the peculiarity of 'Alice' string, since it is a branch line of the space onto 'negative' and 'positive' sheets, forming a gate to the mirror 'Alice' world.

normalization of the wave functions. All that shows us the serious problems with a straight approach and justifies the reason for the treatment of the above combined Dirac-Kerr model. Although it is apparently not a unique possible model. One of the other prospective approaches we intend to consider is the treatment of a local field theory based on the stringy character of the complex Kerr source. In such a model the initially massless Dirac field is related with the sources distributed over the worldsheet of the complex Kerr string. In fact, the twistor lines adjoined to each point of the considered above complex Kerr string may be carriers of the massless Dirac field, forming a sort of twistor-string [13, 33]. The massive Dirac equation have to appear in such a model as a zero mode equation, i.e. as an equation for the massless Dirac field averaged over the complex Kerr string, similar to the appearance of mass in the massless dual string models.

6. Other Aspects of the Extended Kerr Electron.

Regularized source. The twosheeted topology of the Kerr geometry caused long discussion on the problem of Kerr source. Series of the papers has been devoted to an alternative approach avoiding the twosheetedness. Israel [2] suggested to truncate negative sheet along the disk $r = 0$, which resulted in a disk-like source of the Compton size with a singular distribution of matter $\delta(r)$. Subsequent investigations showed that such a disk has to be rigidly rotating and built of exotic superconducting matter. An important correction was given by López [8], who shifted the surface of the disk to $r = r_e = e^2/2m$. The resulting source is the relativistically rotating oblate ellipsoidal shell having Compton radius and the thickness corresponding to classical radius of the electron r_e . The resulting source turns out to be regularized; however it contains a singular matter distribution on the shell. López showed that gravity gives a very essential contribution to the mass. The subsequent steps were related to the treatment of the source in the form of a relativistically rotating bag filled by a false vacuum [30, 31]. In such a model the local gravitational field will be extremely small in all the points of space-time which turns out to be really Minkowskian everywhere. However, it was shown in [15] that, in spite of the very small local contribution, *gravity possesses exclusively strong non-local effect*; in fact it provides regularization, determining the point of phase transition from external (true) electro-vacuum of the Kerr-Newman solution to the regular false vacuum inside the bag. It is expected that such smooth superconducting sources may be formed by Higgs fields in a supersymmetric version of the $U(1) \times \tilde{U}(1)$ field model. An image of corresponding regularized Kerr source is shown on the fig.3.

Twistors and scattering. One of the most problematic and frequently asked questions concerns the seeming contradiction between the large Compton size of the Kerr electron and the widespread statement on the point-like structure of electron obtained in the experiments on deep inelastic scattering. The explanation suggested in [13] is as follows. The momentum of a massive particle is represented as a sum of the lightlike parts p_L^μ and p_R^μ . For relativistic boosts we have usually either $p_L \ll p_R$ or $p_L \gg p_R$, which determines the sign of helicity. As a result one of the axial semi-strings turns out to be strongly dominant and another one represents only a small correction, which allows to use the perturbative twistor-string model for the scattering [32, 33], which is based on a reduced description in terms of the lightlike momentums and helicities. So, the relativistic scattering is determined only by one of the axial half-strings. One can conjecture that *the Kerr disk of the Compton size may*

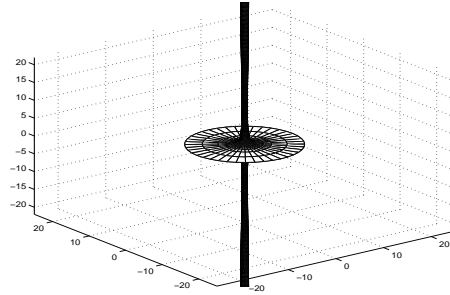

Figure 3. Kerr's electron dressed by Higgs field: relativistic disk and two axial half-strings, carriers of the wave function.

be observed only for polarized electrons in the low-energy experiments with a very soft resonance scattering.

One more question is related with the usefulness and/or necessity of the twistor approach. First of all twistors are absolutely necessary to determine exact form of the Kerr geometry in general case apart from the case of a standard Kerr-Newman form. Second, a very important application is related to discussed above twistor-string theory for scattering at high energies. Next, there is evidence that twistors may play principal role for the space-time description of interactions at any energies. It follows from the treatment of the exact multiparticle Kerr-Schild solutions which were obtained recently, using generating functions of the Kerr theorem $F(Y)$, having higher degrees in Y . Forming the function F as a product of a few one-particle functions in the form of the known blocks $F_i(Y)$, i.e. $F(Y) \equiv \prod_{i=1}^k F_i(Y)$, one obtains multiparticle solutions in which interaction between particles occurs via a common singular twistor line [26].

Finally, it should be noted that the associated with Kerr geometry Minkowski space-time has indeed a twofold topology, and the usual Fourier transform does not work for the functions formed by complex shift. Thereby, the traditional for QED transform to the momentum space cannot be performed in this case. Meanwhile, at least the wave functions and S-matrix turns out to be well defined by transform to twistors space [33] which takes in some sense an intermediate position between the coordinate and momentum space. The corresponding twistor transform is obtained from coordinate representation by a Radon transform [34] which represents a generalization of the usual Fourier transform.

The formalism based on twistor transform seems to be closely adapted to the local and topological quantum field theories. In particular, as it was shown in [33], the typical scattering of plane waves is replaced with the scattering of the wave functions having the support on singular twistor lines, which seems to be very perspective for description of the strongly polarized wave functions on the Kerr background.

6.1. Acknowledgments

Author wishing to acknowledge Organizing committee of the QFEXT'07 conference for very kind invitation and financial support. This work was supported by RFBR grant 08-00234.

References

- [1] B. Carter, Phys. Rev. **174**, 1559 (1968).
- [2] W. Israel, Phys. Rev. D **2**, 641 (1970).
- [3] G.C. Debney, R.P. Kerr, A.Schild, J. Math. Phys. **10**, 1842 (1969).
- [4] A.Ya. Burinskii, Sov. Phys. JETP, **39** 193 (1974); Russ. Phys. J. **17** 1068 (1974).
- [5] D. Ivanenko and A.Ya. Burinskii, Russ. Phys. J. **18**, iss.5, 721 (1975).
- [6] A.Ya. Burinskii, *Strings in the Kerr-Schild metrics* In: "Problems of theory of gravitation and elementary particles", **11**, 47 (1980), Moscow, Atomizdat, (in Russian).
- [7] D. Ivanenko and A.Ya. Burinskii, Russ. Phys. J. **21**, 932 (1978).
- [8] C.A. López, Phys. Rev. **D 30**, 313 (1984).
- [9] A.Ya. Burinskii, Phys. Lett. **A 185**, 441 (1994); *String-like Structures in Complex Kerr Geometry*. (gr-qc/9303003.) In: "Relativity Today", Edited by R.P.Kerr and Z.Perjés, Akadémiai Kiadó, Budapest, 1994, p.149.
- [10] A. Burinskii, Class. Quant. Grav. **16**, 3497 (1999).
- [11] A. Burinskii, Phys. Rev. D **68**, 105004 (2003).
- [12] H. I. Arcos, J. G. Pereira, Gen. Rel. Grav. **36**, 2441 (2004).
- [13] A. Burinskii, Phys. Rev. D **70**, 086006 (2004); *Dirac – Kerr electron*, hep-th/0507109 (to appear in Grav. Cosm.); Czech. J. Phys. **55**, A261 (2005).
- [14] C.L. Pekeris and K. Frankowski, Phys. Rev. A **39**, 518 (1989).
- [15] A. Burinskii, J. Phys. A: Math. Gen. **39**, 6209 (2006).
- [16] K. Rosquist, Class. Quant. Grav. **23**, 3111 (2006).
- [17] E.T. Newman, J. Math. Phys. **14**, 102 (1973), R.W. Lind and E.T.Newman, J. Math. Phys. **15**, 1103 (1974).
- [18] A. Burinskii and R.P. Kerr, *Nonstationary Kerr Congruences*, gr-qc/9501012.
- [19] A. Burinskii, Phys. Rev. D **67**, 124024 (2003).
- [20] R. Penrose, J. Math. Phys. **8** 345 (1967).
- [21] D.Kramer, H.Stephani, E. Herlt, M.MacCallum, "Exact Solutions of Einstein's Field Equations", Cambridge Univ. Press, 1980.
- [22] A. Burinskii, *Axial Stringy System of the Kerr Spining Particle*, hep-th/0403212, Grav. Cosm., **10**, 50 (2004).
- [23] A. Burinskii and G. Magli, Phys. Rev. **D 61**, 044017 (2000).
- [24] A. Burinskii, E. Elizalde, S. R. Hildebrandt and G. Magli, ArXiv: 0705.3551 [hep-th].
- [25] V.B. Berestetsky, E.M. Lifshitz, L.P. Pitaevsky, "Quantum Electrodynamics (Course Of Theoretical Physics, 4)", Oxford, UK: Pergamon (1982).
- [26] A. Burinskii, Int. J. Geom. Methods Mod. Phys. **4**, 437 (2007); Grav. Cosm. **11**, 301 (2005) (hep-th/0506006).
- [27] A.I. Akhiezer and V.B. Berestetsky, "Quantum Electrodynamics" (in russian) , Moscow, "Nauka", 1981.
- [28] R.P. Feynman, "The Theory of Fundamental Processes", Calif. Inst. of Techn., New York 1961.
- [29] A. Burinskii, Phys. Rev. **D 52**, 5826 (1995)
- [30] A. Burinskii, Grav. Cosm. **8**, 261 (2002).
- [31] A. Burinskii, E. Elizalde, S. R. Hildebrandt and G. Magli, Phys. Rev. **D 65**, 064039 (2002).
- [32] V.P. Nair, Phys. Lett. **B 214**, 215 (1988).
- [33] E. Witten, Comm. Math. Phys. **252**, 189 (2004) (hep-th/0312171).
- [34] I.M.Gelfand, M.I.Graev and N.Ya.Vilenkin, "Generalized Functions", Ser.5, Phys. Math. Publ., Moscow 1962, (in Russian).