

Radiation Testing of Consumer High-Speed LSI Chips for the Next Space VLBI Mission, VSOP-2

Kiyooki WAJIMA^{1,2}, Noriyuki KAWAGUCHI^{3,4}, Yasuhiro MURATA^{5,6}, and Hisashi HIRABAYASHI⁵

¹*Korea Astronomy and Space Science Institute, 61-1 Hwaam-dong, Yuseong, Daejeon 305-348, Korea*

²*Department of Physics, Faculty of Science, Yamaguchi University, 1677-1 Yoshida, Yamaguchi, Yamaguchi 753-8512
wajima@yamaguchi-u.ac.jp*

³*National Astronomical Observatory of Japan, 2-21-1 Osawa, Mitaka, Tokyo 181-8588*

⁴*Department of Astronomical Science, The Graduate University for Advanced Studies,
2-21-1 Osawa, Mitaka, Tokyo 181-8588*

⁵*Institute of Space and Astronautical Science, Japan Aerospace Exploration Agency,
3-1-1 Yoshinodai, Sagami-hara, Kanagawa 229-8510*

⁶*Department of Space and Astronautical Science, The Graduate University for Advanced Studies,
3-1-1 Yoshinodai, Sagami-hara, Kanagawa 229-8510*

(Received 2006 December 15; accepted 2007 August 24)

Abstract

We performed two types of radiation testing on high-speed LSI chips to test their suitability for use in wideband observations by the Japanese next space VLBI mission, VSOP-2. In the total ionization dose experiment we monitored autocorrelation spectra which were taken with irradiated LSI chips and the source current at intervals up to 1,000 hours from the ionization dose, but we could not see any change of these features for the chips irradiated with dose rates expected in the VSOP-2 mission. In the single event effect experiment, we monitored the cross correlation phase and power spectra between the data from radiated and non-radiated devices, and the source current during the irradiation of heavy-ions. We observed a few tens of single event upsets as discrete delay jumps for each LSI. We estimated the occurrence rate of single events in space as between once a few days to once a month. No single event latch-up was seen in any of the LSIs. These results show that the tested LSIs have sufficient tolerance to the environment for space VLBI observations.

Key words: space vehicles: instruments — instrumentation: interferometers — techniques: interferometric

1. Introduction

The VLBI (Very Long Baseline Interferometry) technique allows high-resolution astronomical images to be obtained from observations using widely separated radio telescopes (Thompson et al. 2001). This technique enables extremely high angular resolutions, of less than 1 milliarcsecond, to be obtained and intercontinental VLBI observations are now routinely carried out (Zensus 1997; Kellermann, Moran 2001).

The technique of space VLBI uses an orbiting radio telescope(s) in addition to ground radio telescopes to achieve even further improvements in angular resolution. The first space VLBI mission, VSOP (the VLBI Space Observatory Programme), was realized with the space VLBI spacecraft HALCA (Highly Advanced Laboratory for Communications and Astronomy), which was launched in 1997 (Hirabayashi et al. 1998; 2000).

Following the successes of VSOP, the next space VLBI mission, VSOP-2, was planned and selected as a scientific mission, ASTRO-G, in the Japan Aerospace Exploration Agency (JAXA) with a proposed launch in 2012 (Hirabayashi et al. 2004; Murata 2005). In this paper we report the results of radiation testing of high-speed

commercial off-the-shelf (COTS) LSI chips as one of development items for higher sensitivity space VLBI observations.

The minimum sensitivity, S_{\min} , in VLBI observations of continuum sources can be derived as

$$S_{\min} = 2k_{\text{B}}R_{\text{SN}}\sqrt{\frac{T_{\text{sys1}}T_{\text{sys2}}}{A_{\text{e1}}A_{\text{e2}}}}\frac{1}{\sqrt{2\Delta B\tau}}, \quad (1)$$

where k_{B} is Boltzmann's constant, R_{SN} is the signal-to-noise ratio of the observation signal, $T_{\text{sys}n}$, $A_{\text{e}n}$ are the system noise temperature and the antenna effective aperture in station n , respectively, ΔB is the bandwidth, and τ is the integration time. In VLBI, the radio signals are usually digitized and accumulated at the Nyquist rate of $2\Delta B$, and thus one can detect fainter objects with higher speed sampling. Expansion of the bandwidth by raising the sampling speed is therefore a key issue for high sensitivity VLBI observations. This is particularly true for space VLBI, where the dimensions of the rocket nose fairing place strong constraints on the antenna size. The VSOP-2 spacecraft will have the capability of a data processing rate of 1 gigabit per second (Gbps), as compared to 128 Mbps for HALCA spacecraft. While data sampling and recording at more than, or equal to, 1 Gbps have al-

ready been accomplished with ground-based VLBI systems (Nakajima et al. 2001), it has not yet been realized in an onboard system, in part because to date there have been very few missions that require such a high speed sampling system. Radiation testing of COTS LSI chips is therefore indispensable to realize wideband space VLBI observations.

In addition, we must consider the orbit of the space VLBI spacecraft. In space VLBI observations, higher quality radio images can be obtained by placing the spacecraft in an elliptical orbit. For example, HALCA had an elliptical orbit with an apogee height of 21,400 km and a perigee height of 560 km, and the VSOP-2 spacecraft will have a similar orbit to that of HALCA, with nominal apogee and perigee height of 25,000 km and 1,000 km, respectively. However, it is a very severe environment for the spacecraft because such an orbit passes through the inner Van Allen belt twice per revolution. In 2002, the Mission Demonstration Satellite-1 (MDS-1, later named TSUBASA) was launched by the National Space Development Agency of Japan (NASDA) and placed in an elliptical orbit (an apogee height of 35,696 km and a perigee height of 500 km), which was similar to that of HALCA. MDS-1 was equipped with several COTS products, such as solar cells, semiconductor and memory devices, in order to verify their tolerance in the space environment (Shindou et al. 2002). However, it was not equipped with the high speed LSI chips required in the VSOP-2 mission, and therefore radiation testing of such chips is necessary.

For the above-mentioned reasons, we performed radiation testing of high speed COTS devices. In section 2, we summarize the experiments. Overviews and results of the two types of experiments are given in sections 3 and 4. In section 5 we discuss the suitability of the tested devices for the space environment.

2. Summary of the Experiments

The experiments were carried out at the Takasaki Institute of the Japan Atomic Energy Research Institute (JAERI). The tested devices were a decision circuit (1-bit quantization circuit; hereafter DEC) and a demultiplexer (converting one data stream into 16-bit parallel data; hereafter DEMUX), both of which are gallium arsenide (GaAs) MESFET devices having gate lengths of $0.2 \mu\text{m}$ (see figure 1). These are available for ground communications. These have the capability of a maximum data processing rate of 10 Gbps and are used in an 8 Gbps sampler which is under development at the National Astronomical Observatory of Japan (NAOJ) (Okiura et al. 2002).

We have performed two types of radiation testing; a total ionization dose (TID) experiment using a cobalt-60 source, and a single event effect (SEE) experiment by irradiation of heavy-ions. If we assume a nominal orbit for the VSOP-2 spacecraft, as mentioned in section 1, and nominally a one year lifetime, then 1 kGy (an unit 'gray' represents an absorbed dose in the dimension of J kg^{-1}) of total ionizing radiation and a maximum incidence level

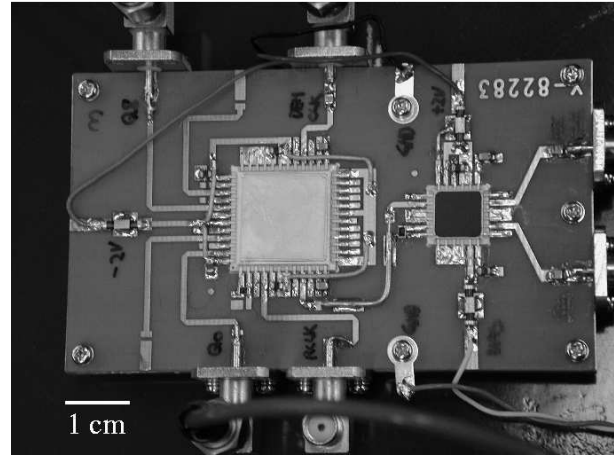

Fig. 1. Tested devices; a demultiplexer (left) and a decision circuit (right).

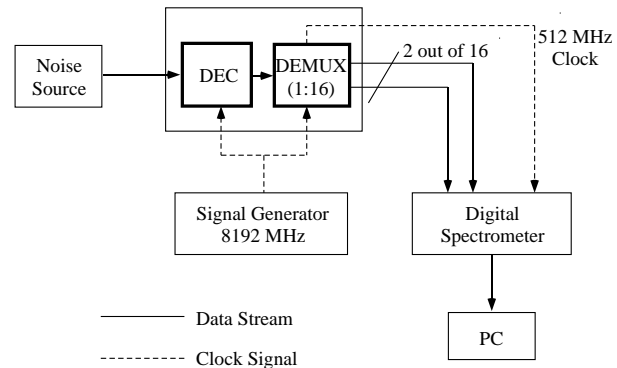

Fig. 2. Schematic diagram of the power spectra measurement system for the TID experiment.

of $80 \text{ MeV mg}^{-1} \text{ cm}^2$ for the linear energy transfer (LET; energy loss rate of a particle along its trajectory in a material) are required.

3. Total Ionization Dose Experiment

3.1. Overview of the Experiment

In the TID experiment six sets of DEC and DEMUX were prepared, five sets of which served as test devices and one of which was used as a reference. Irradiation testing was carried out at a dose rate of 2 kGy hr^{-1} , and the absorbed dose toward each device measured by the dosimeter was 0.73 kGy, 1.70 kGy, 1.90 kGy, 5.01 kGy, and 9.95 kGy. After the irradiation, autocorrelation spectra were taken using the measurement system shown in figure 2. In this system the white noise generated by the noise source is one-bit digitized by the DEC and one data stream is parallelized into 16 streams by the DEMUX. In our experiment, however, only two data streams out of 16 parallel outputs from the DEMUX were used for correlation due to limitations of the processing speed after the DEMUX.

Autocorrelation spectra were taken seven times after the irradiation (8, 24, 72, 100, 150, 300, and 1,000 hours)

and compared with the spectrum taken before irradiation. The source current of each LSI was also monitored up to 1,000 hours from the experiment, with sampling times of 10 seconds during the irradiation and an hour for monitoring after the experiment.

3.2. Results

Part of autocorrelation spectra results from the TID experiment are shown in figure 3 (a), (b), and (c). The horizontal and vertical axes show the frequency channel (one channel corresponds to a bandwidth of 4 MHz) and the power in arbitrary units, respectively. The peak at channel 32 in each graph is a monochromatic signal injected as a reference and it is adjusted to a similar power level to the wideband noise. Figure 3 (d) shows the result of subtraction of power in panel (b) and (c) from panel (a), assuming as a reference. The standard deviation for each graph compared to (a), excluding channels 0 (DC offset can be seen) and 32 (a monochromatic signal is injected) is 0.260 and 0.095, showing little change in amplitude before and after irradiation. In order to check the influence of irradiation, we also calculated the cross-correlation coefficient between the power spectra of the reference and the tested device. In all combinations, including the case illustrated by figure 3, cross-correlation coefficients are larger than 0.993, corresponding to the amplitude displacement of less than 0.03 dB. If this amplitude displacement is produced by the TID effect over the lifetime of VSOP-2 mission, we conclude that the displacement within a typical duration time per observation (about 8 hours) can be ignored.

Figure 4 shows the source current of all DEC and DEMUX samples during and after the experiment. There are several discontinuities in each of the sampled data because it was necessary to mount and unmount each LSI in order to take autocorrelation spectra. In all DEC's we could see slight variations in the source current up to 1%. On the other hand, an abrupt current variation in the DEMUX with 10 kGy irradiation was observed 500 hours after the experiment. We could not determine whether this variation was due to the excess of irradiation, or to gamma-ray irradiation itself irrespective of the total dose. We should perform a further experiment in order to specify the cause, although, if the former case applies, we can conclude that these LSIs are able to be used in space as the total dose of 10 kGy corresponds to that 10 times longer than the planned lifetime of the VSOP-2 spacecraft.

4. Single Event Effect Experiment

4.1. Overview of the Experiment

In the SEE experiment, four sets of DEC's and DEMUX's were prepared, three sets of which served as tested devices and one set of which was the reference. Heavy ions, krypton (Kr, $LET = 6.33 \text{ MeV mg}^{-1} \text{ cm}^2$), argon (Ar, $LET = 15.3 \text{ MeV mg}^{-1} \text{ cm}^2$), and neon (Ne, $LET = 39.9 \text{ MeV mg}^{-1} \text{ cm}^2$), were used to irradiate either DEC or DEMUX. Because of a problem in the beam line system, experiments using higher LET ions, such as xenon

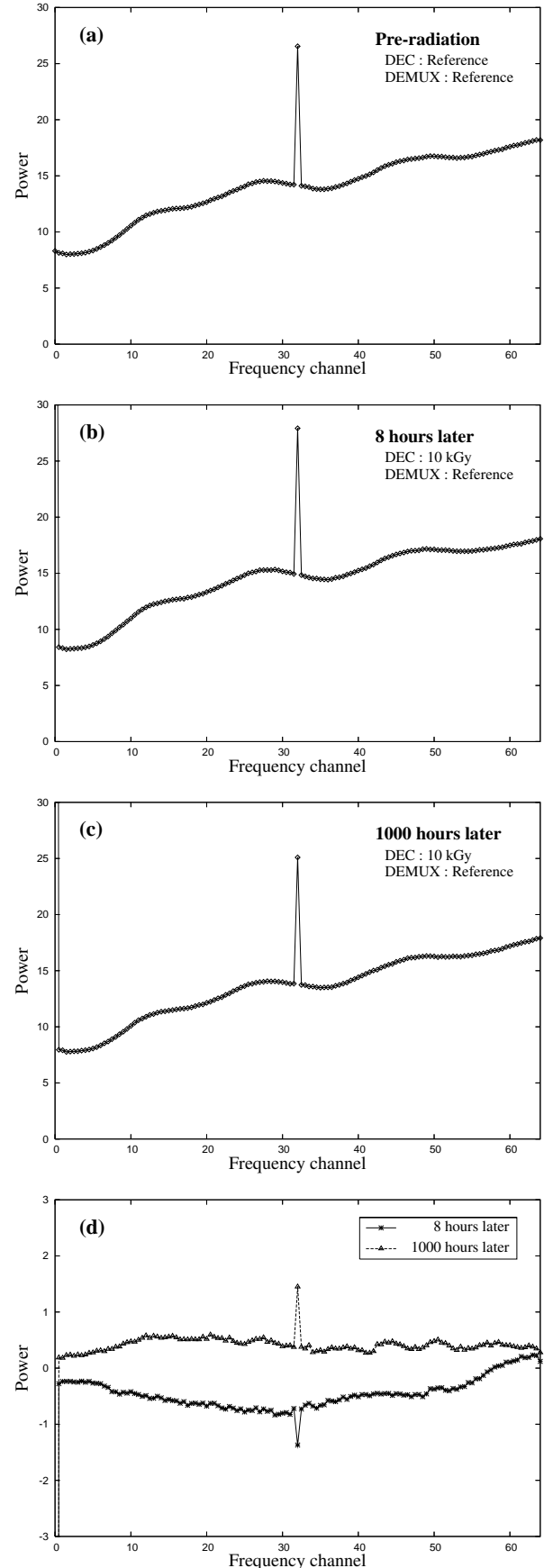

Fig. 3. Power spectra in the TID experiment. (a) Pre-radiation, (b) 8 hours after the experiment; DEC: 10 kGy irradiation, DEMUX: reference, (c) 1,000 hours after the experiment; DEC: 10 kGy irradiation, DEMUX: reference, (d) result of subtraction of panel (b) and (c) from panel (a), used as a reference.

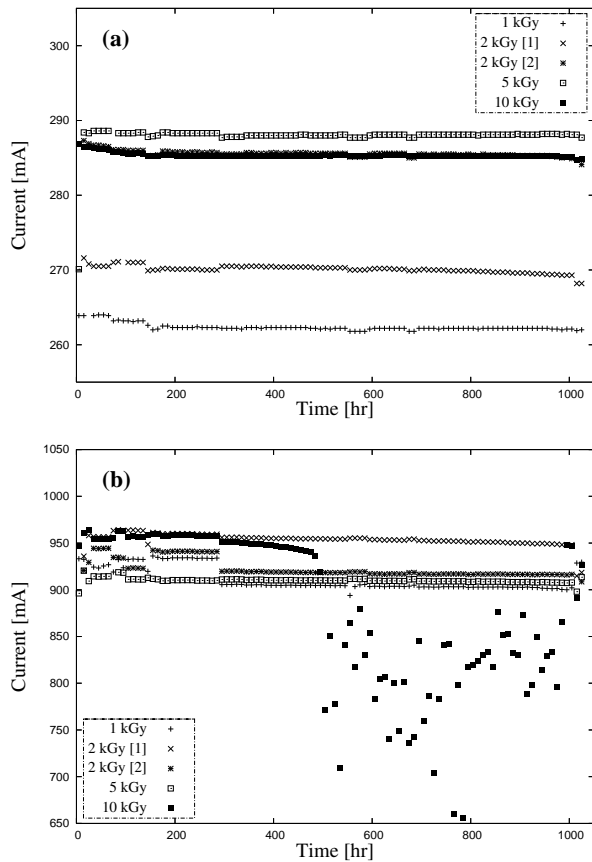

Fig. 4. The source current in the TID experiment; (a) DEC and (b) DEMUX.

(Xe, $LET = 62.9 \text{ MeV mg}^{-1} \text{ cm}^2$), were not performed. In order to check the influence of the heavy-ion irradiation, the cross-correlation between the data from radiated and non-radiated devices were monitored in real-time during the experiment using the measurement system shown in figure 5. As in the TID experiment, DEC and DEMUXs were driven with an 8 GHz clock and two data streams out of 16 parallel outputs from DEMUX were used for cross-correlation. The source current of the devices was also monitored during the irradiation in order to check for the occurrence of a single event latch-up.

In the standard radiation testing of memory devices, known data are stored into a memory before irradiation and the number of inverted bits is counted after the testing. One therefore cannot check the influence of the irradiation effect in real-time, while in our measurement method one can directly monitor the influence of the heavy-ion irradiation.

Before the experiment we checked the cross correlation spectrum under the non-radiated condition and confirmed that the cross-correlation phase had no variation with time.

4.2. Results

Part of the result in the SEE experiment is shown in figure 6. The horizontal and vertical axes show the ra-

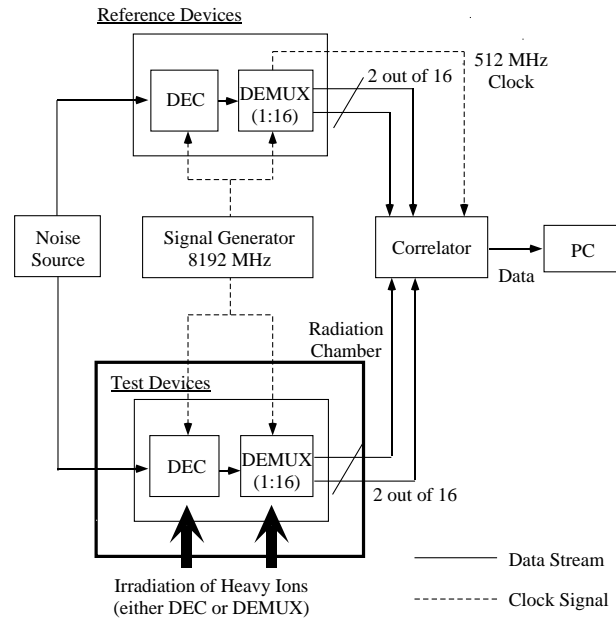

Fig. 5. Schematic diagram of the cross correlation measurement system for the SEE experiment.

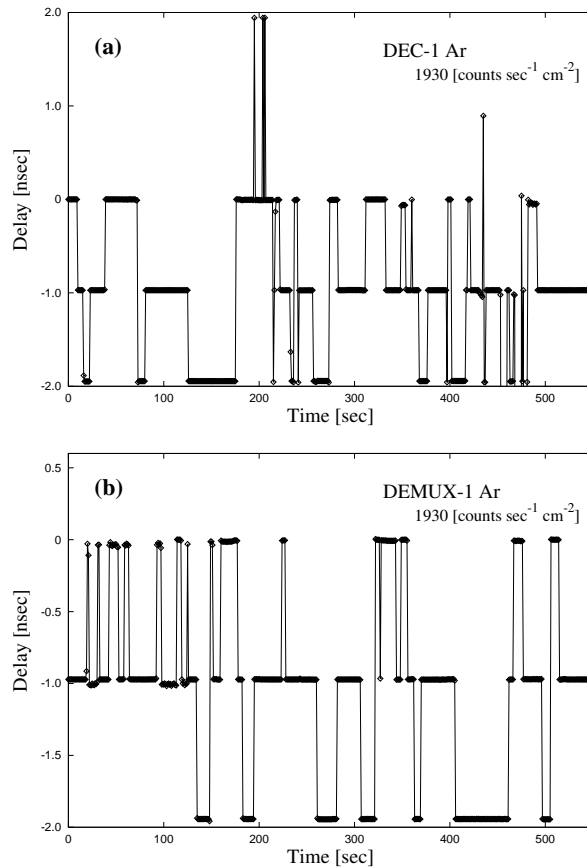

Fig. 6. Measured delay for the Ar irradiation of (a) DEC and (b) DEMUX.

Table 1. SEU counts for each heavy ion.*

	Ne	Ar	Kr
Particle injection rate [counts cm ⁻² sec ⁻¹]	5,153	1,930	783
Total number of particles [×10 ⁵ counts cm ⁻²]	10	10	2.3
DEC-1	12	32	16
DEC-2	–	24	–
DEC-3	–	29	–
DEMUX-1	12	35	20
DEMUX-2	–	38	–
DEMUX-3	–	53	–

* – denotes experiments not executed.

diation time in seconds and the delay time between the reference and tested devices in nanoseconds, respectively. In the experiment shown in figure 6, Ar was irradiated at a rate of 1,930 particles cm⁻² sec⁻¹, for a total of 10⁶ particles. The delay time was derived from the observation result of the time variation of the cross-correlation phase, and a moving image of the cross-correlation phase in the real-time observation result is available online ¹.

In the SEE experiment we had 12 – 53 single event upsets (SEUs) for each LSI and heavy-ion (see table 1). Table 1 shows that the SEU counts of the DEMUX are slightly larger than, or equal to, those of the DEC in all combinations of ions. This result may reflect differences in tolerance for the space environment between the DEC and DEMUX, although this conclusion is necessarily somewhat tentative because of limited number of samples. We also found SEUs as discrete $n\pi$ jumps in the cross-correlation phase.

We have also monitored the source current of each LSI under radiation, but did not see an abrupt change for any of LSIs (see figure 7).

5. Discussion

As mentioned in section 4, we could see SEUs as discrete $n\pi$ jumps of the cross-correlation phase in both the DEC and DEMUX data. In the SEE experiment the DEC and DEMUX chips of both the reference and tested paths were driven by the 8 GHz clock and two data streams, Q0 and Q8, out of 16 parallel outputs (Q0, Q1, ..., Q15 in order of time) from the DEMUX were used for cross-correlation (see figure 5). Data processing was therefore done equivalently by the sampling rate of 1 Gbps, and a displacement of one data sample between each data stream corresponds to a one nanosecond delay. From these observation results we consider that observed SEU in the DEMUX is due to the occurrence of a clock reset in the DEMUX by the heavy-ion injection. On the other hand, we could also see discrete $n\pi$ jumps of the cross-correlation phase in irradiation of the DECs, even though the clock output was not used to drive the devices downstream (see figure 5). We

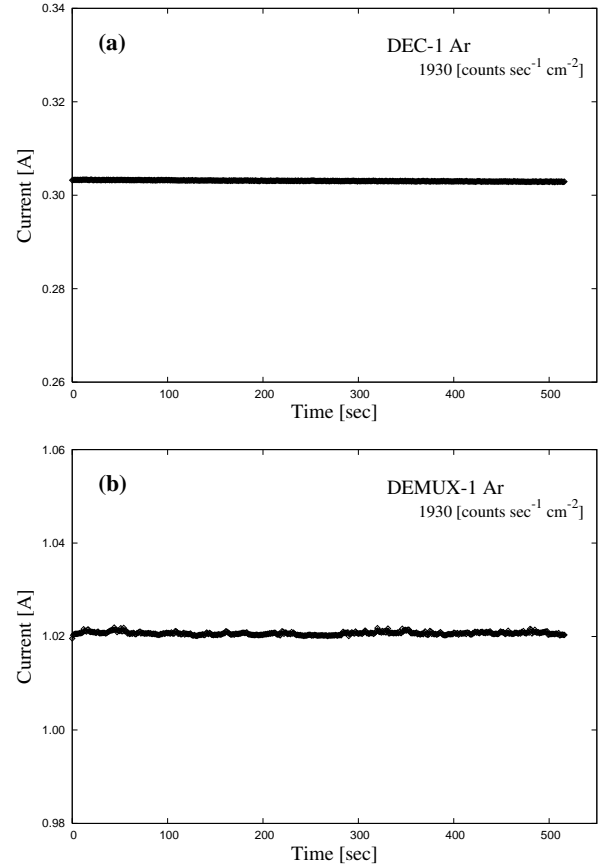

Fig. 7. Source current during Ar irradiation; (a) DEC and (b) DEMUX.

consider that the heavy-ion injection affects an internal register circuit of the DEC giving rise to an SEU.

In the SEE experiment we had a few tens of SEUs for each LSI and heavy-ion. We derived the following ‘SEU cross-section’ for each heavy-ion;

$$\begin{aligned} \text{SEU cross section [cm}^2 \text{ chip}^{-1}] \\ &= \frac{\text{total SEU number [counts chip}^{-1}]}{\text{number of the heavy ion particles [counts cm}^{-2}]} \end{aligned}$$

Figure 8 shows the relation between the LET and the SEU cross-section for DEC-1 and DEMUX-1 for each heavy-ion.

We estimate the occurrence rate of SEUs for each LSI in space using the CREME96 (Cosmic Ray Effects on Micro-Electronics) Program (Tylka et al. 1997)² with the following procedure. First, the critical charge Q_c [pC], the minimum charge deposition required to produce an SEU, is calculated by the following:

$$Q_c = \frac{L_{th} T \rho e}{E}, \quad (2)$$

where L_{th} is the threshold effective LET in MeV mg⁻¹ cm², T is the device thickness in μm , ρ is the material density (5.32 g cm⁻³ for GaAs), e is the

¹ See <http://wwwj.vsoip.isas.jaxa.jp/vsop2/radtest/Radtest.html>

² See also <https://creme96.nrl.navy.mil/>

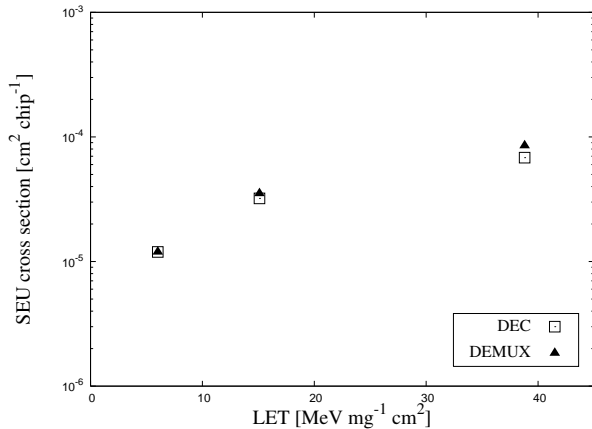

Fig. 8. SEU cross section of DEC-1 and DEMUX-1 for each heavy-ion.

elementary electric charge, and E is the minimum energy needed to create one electron-hole pair (4.8 eV for GaAs). We derived Q_c from the device size and the expected L_{th} , which is equal to one hundredth of the saturated SEU cross section, σ_s , from figure 8. Finally, we can calculate the occurrence rate of SEU using derived Q_c along with orbital elements of the VSOP-2 spacecraft. Although we cannot precisely derive L_{th} because we have not performed the radiation testing using heavy-ions with lower LETs, if we assume L_{th} to be 1, 2, 3, or 4 (MeV mg⁻¹ cm²), the occurrence rate of SEU for both DEC and DEMUX can be estimated as about once per 3.5, 14.1, 31.5, and 56.1 days, respectively.

The occurrence rate of SEU for each LSI seems to be slightly higher than that for other space-qualified devices, however we believe that it is acceptable for space VLBI observations for the following reason. In VLBI, the digitized radio-astronomical data are usually recorded on a magnetic storage media at each station and cross-correlation processing is performed by a correlator in order to detect interferometric fringes. When performing the cross-correlation, the expected arrival time of identical wavefront at each station is calculated on the basis of the coordinates of the radio source, the position of each antenna, and earth rotation parameters, and those are subtracted from the original data in advance. Finally we search for the maximum cross-correlation coefficient in the residual delay (τ_{res}) and residual delay-rate ($\dot{\tau}_{res}$) plane. In space VLBI there are relatively large errors in the station position of the spacecraft compared to those of ground radio telescopes because of the orbital motion, and so correlators used for processing of space VLBI observations use wider τ_{res} and $\dot{\tau}_{res}$ ranges to raise the chance of fringe detection. For example, the Space VLBI correlator in NAOJ has the capability of a maximum τ_{res} of 128 μ sec, and one can carry out time integration if fringes are found within this τ_{res} window. A few nanoseconds delay, which was observed in the SEE experiment, is much smaller than the τ_{res} window of the correlator and therefore we can perform space VLBI observations using these LSI chips. Even if

one nanosecond delay observed in the SEE experiment occurs through observations, the coherence loss in VLBI observations of continuum sources is about 3% and it is acceptable to accomplish scientific goals by the VSOP-2 mission.

We thus have obtained promising prospects for the use of these LSIs in the VSOP-2 project through these experiments, however we have not performed the SEE experiment on the condition of higher LET irradiation with Xe or of lower LET irradiation with protons or oxygen. These are future tasks in order to determine L_{th} and σ_s precisely.

6. Conclusion

We performed two types of radiation testing of high-speed LSI chips for wideband space VLBI observations. In these experiments we monitored the autocorrelation (TID) and cross-correlation (SEE) spectra and the source current. In the SEE experiment a few tens of single event upsets were seen for each LSI, and we estimated the occurrence rate of single events in space as between once a few days to once a month, which does not affect space VLBI observations. We did not see an abrupt change of the source current in any of LSIs.

The measurement method applied in the SEE experiment is useful for radiation testing of similar types of LSI chips since one can monitor the appearance of SEUs in real-time.

The authors would like to thank Drs. Sachiko K. Okumura and Satoru Iguchi of NAOJ, Japan Communication Equipment (Nihon Tsushinki) Co. Ltd., and High-Reliability Components (HIREC) Co. Ltd. for valuable comments and technical supports on the experiments. We are grateful to the referee, Dr. Jonathan D. Romney, for valuable comments to improve the paper. We also thank Dr. Philip G. Edwards for polishing the manuscript.

References

- Hirabayashi, H., et al. 1998, *Science*, 281, 1825
- Hirabayashi, H., et al. 2000, *PASJ*, 52, 955
- Hirabayashi, H., et al. 2004, *Proc. SPIE*, 5487, 1646.
- Kellermann, K. I., & Moran, J. M. 2001, *ARA&A*, 39, 457
- Murata, Y. 2005, *JKAS*, 38, 97
- Nakajima, J., Koyama, Y., Sekido, M., Kurihara, N., Kondo, T., Kimura, M., & Kawaguchi, N. 2001, *Experimental Astron.*, 11, 57
- Okiura, M., Iguchi, S., Okumura, S. K., Momose, M., Matsumoto, K., & Kawaguchi, N. 2002, *Proc. IEEE MTT-S Intl. Microwave Symp.*, 1, 485
- Shindou, H., et al. 2002, *Proc. 5th Intl. Workshop on Radiation Effects on Semiconductor Devices for Space Application*, 39
- Thompson, A. R., Moran, J. M., & Swenson, G. W., Jr. 2001, *Interferometry and Synthesis in Radio Astronomy*, 2nd ed., (John Wiley & Sons, New York)
- Tylka, A. J., et al. 1997, *IEEE Trans. Nuclear Science*, 44, 2150
- Zensus, J. A. 1997, *ARA&A*, 35, 607